

THIS DRAWING IS UNPUBLISHED.

RELEASED FOR PUBLICATION

20

© COPYRIGHT 20 BY - ALL RIGHTS RESERVED.

REVISIONS

P	LTR	DESCRIPTION	DATE	DWN	APVD
	A	INITIAL	15MAY2015	DW	CW
	A1	ECR-16-002757	24FEB2016	RL	CW

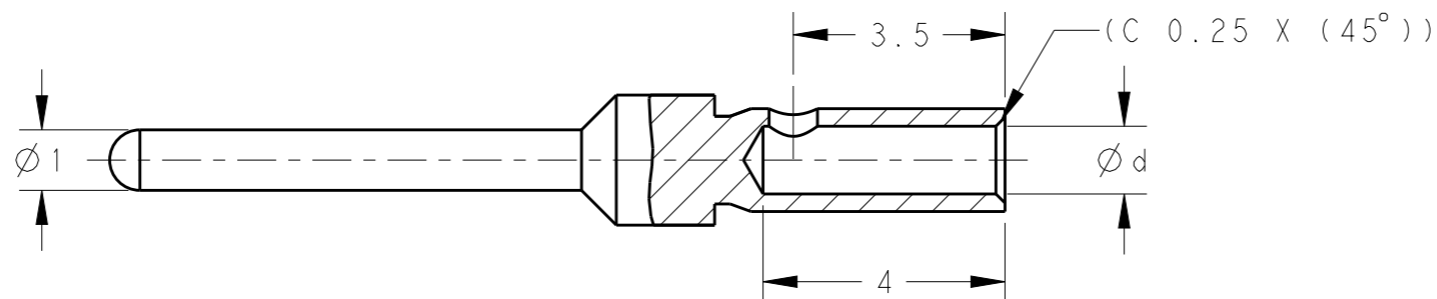
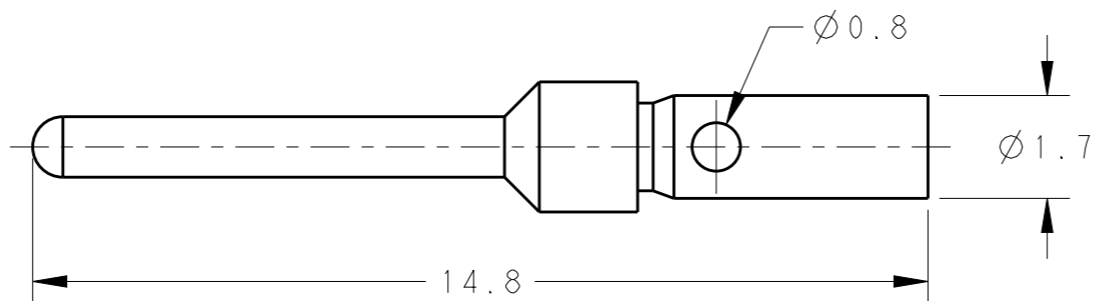
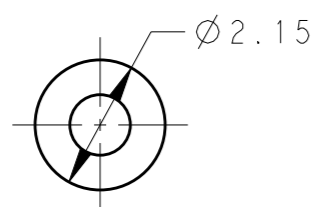
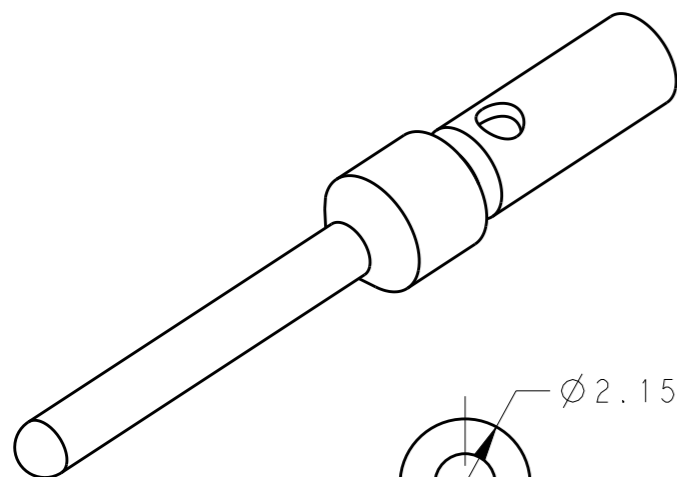

NOTES:

- 1. TECHNICAL CHARACTERISTICS:  
 CONTACT MATERIAL: BRASS  
 SURFACE PLATING:  
 SILVER PLATING:  $\geq 2\mu\text{m}$   
 GOLD PLATING:  $\geq 0.75\mu\text{m}$   
 WIRE RANGE: 0.08-0.52 mm<sup>2</sup> (28-20 AWG)  
 OPERATION TEMPERATURE: -40-+125°C

注释:

- 1. 技术参数:  
 公针材料: 黄铜  
 表面电镀:  
 镀银:  $\geq 2\mu\text{m}$   
 镀金:  $\geq 0.75\mu\text{m}$   
 接线范围: 0.08-0.52 mm<sup>2</sup> (28-20 AWG)  
 工作温度: -40-+125°C

-	PART NUMBER AFTER PLATING 电镀后料号				$\phi d$	WIRE GAUGE 线规		STRIPPING LENGTH 剥线长度 (mm)
	SILVER PLATING 镀银		GOLD PLATING 镀金			MM <sup>2</sup>	AWG	
PIN CONTACT 公针	CAM-08	T2070001008-000	DAM-08	T2070011008-000	0.7	0.08-0.21	28-24	4.0
	CAM-13	T2070001013-000	DAM-13	T2070011013-000	0.9	0.13-0.33	26-22	
	CAM-33	T2070001033-000	DAM-33	T2070011033-000	1.12	0.33-0.52	22-20	

THIS DRAWING IS A CONTROLLED DOCUMENT.

DIMENSIONS:  
mm

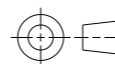

TOLERANCES UNLESS OTHERWISE SPECIFIED:

0 PLC	±-
1 PLC	±-
2 PLC	±-
3 PLC	±-
4 PLC	±-
ANGLES	±-

MATERIAL

FINISH

DWN 15MAY2015

David Wang

CHK 15MAY2015

Chris Wang

APVD 15MAY2015

Xiang Xu

PRODUCT SPEC

108-137064

APPLICATION SPEC

114-137064

WEIGHT

-

Customer Drawing



TE Connectivity

NAME

CAM/DAM  
D-SUB PIN CONTACT

SIZE CAGE CODE DRAWING NO RESTRICTED TO

A3 00779 C-T20700X10XX000 -

SCALE 8:1 SHEET 1 OF 1 REV A1