

4

3

2

1

THIS DRAWING IS UNPUBLISHED.

RELEASED FOR PUBLICATION

20

© COPYRIGHT 20 BY -

ALL RIGHTS RESERVED.

REVISIONS

P	LTR	DESCRIPTION	DATE	DWN	APVD
A1		ECR-15-004309	19MAR2015	DW	CW
A2		ECR-15-007632	25MAY2015	DW	CW
B		ECR-15-013292	24SEP2015	DL	CW
B1		ECR-16-015492	21NOV2016	QY	CW

4X M3 SCREW RECOMMENDED
TIGHTENING TORQUE 0.5Nm
4X M3螺丝, 推荐锁紧力矩0.5Nm

M4 SCREW
RECOMMENDED
TIGHTENING
TORQUE 1.2Nm
M4 螺丝, 推荐锁紧力矩1.2Nm

NOTES:

- TECHNICAL CHARACTERISTICS:
INSULATION MATERIAL: PC
RATED VOLTAGE: 250 V
RATED CURRENT: 10 A
INSULATION RESISTANCE: $\geq 400M\Omega$
RATED IMPULSE VOLTAGE: 2.5 KV
POLLUTION DEGREE: 2
FLAMMABILITY: UL94V-0
MATING CYCLES: 500 CYCLES
WIRE RANGE: 0.14-2.5 mm² (26-14 AWG)
CONTACT TYPE: CRIMP CONTACT
- CONTACT NEED TO BE ORDERED SEPARATELY.
(ORDER No. REFER TO DRAWING: T20200X20XX000)

注释:

- 技术参数:
绝缘材料: PC
额定电压: 250V
额定电流: 10A
绝缘电阻: $\geq 400M\Omega$
额定脉冲电压: 2.5 KV
污染等级: 2
阻燃等级: UL94V-0
插拔次数: 500次
接线范围: 0.14-2.5 mm² (26-14 AWG)
接线类型: 冷压接
- 端子需要单独订购.
(订货号参考图面: T20200X20XX000)

TYPE-1, T2030722201-000, TE LOGO
类型-1, T2030722201-000, TE LOGO

PANEL CUT OUT FOR INSERTS FOR USING
WITHOUT HODDS/HOUSINGS
不用防护外壳时芯件的安装开孔图

THIS DRAWING IS A CONTROLLED DOCUMENT.		DWN	29OCT2014	TE Connectivity	
		CHK	David Wang		
		APVD	Chris Wang		
		NAME	Xiang Xu		
DIMENSIONS: mm		PRODUCT SPEC	108-137043	NAME HDD-072-F	
TOLERANCES UNLESS OTHERWISE SPECIFIED:		APPLICATION SPEC	114-137043	SIZE	A3
0 PLC ±-		WEIGHT	-	CAGE CODE	00779
1 PLC ±-		Customer Drawing		DRAWING NO	T2030722201000
2 PLC ±-				RESTRICTED TO	-
3 PLC ±-				SCALE	1:1
4 PLC ±-				SHEET	1 OF 2
ANGLES ±-		REV	B1		
MATERIAL					
FINISH					

1470-19 (3/13)

THIS DRAWING IS UNPUBLISHED.

RELEASED FOR PUBLICATION

20

© COPYRIGHT 20 BY -

ALL RIGHTS RESERVED.

REVISIONS

P	LTR	DESCRIPTION	DATE	DWN	APVD
-		SEE SHEET 1	-	-	-

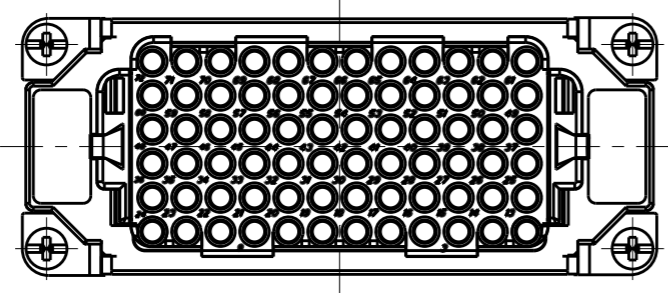

NOTE:
SEE SHEET 1
注释:
见页 1

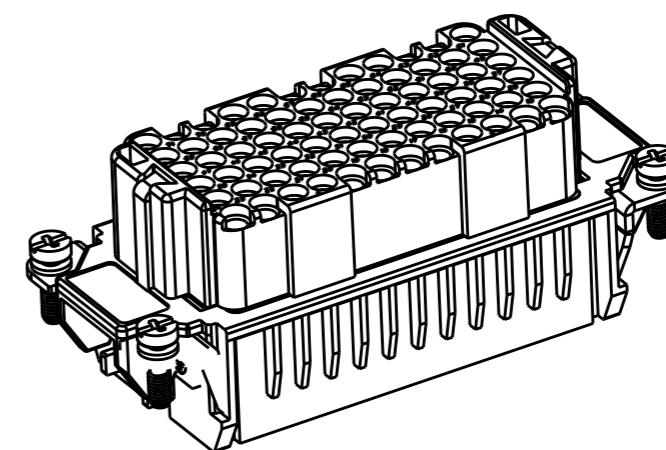
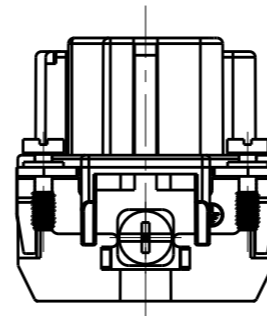
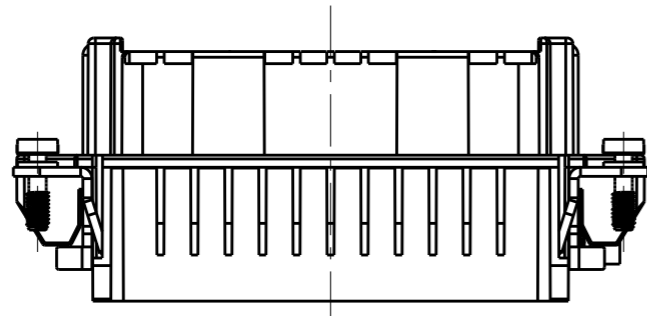

TYPE-2, T2030722201-001, STAINLESS STEEL SCREW, NO LOGO
类型-2, T2030722201-001, 不锈钢螺丝, 无LOGO

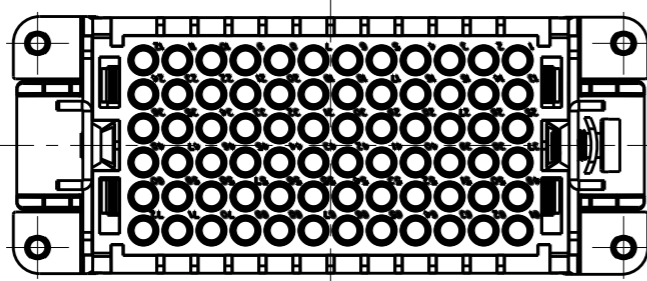

T2030722201-001	HDD-072-F	HDD-072 FEMALE INSERT, CRIMPING SPLIT TYPE, STAINLESS STEEL SCREW, NO LOGO HDD-072 母插, 冷压针分体式, 不锈钢螺丝, 无LOGO	TYPE-2 类型-2
T2030722201-000	HDD-072-F	HDD-072 FEMALE INSERT, CRIMPING SPLIT TYPE HDD-072 母插, 冷压针分体式	TYPE-1 类型-1
PART NUMBER 料号	PART DESCRIPTION 描述		TYPE 类型

ALL DIMENSIONS ARE SAME AS TYPE 1, EXCEPT THOSE DEFINED IN THIS TYPE.
除了在本类型中定义的尺寸外, 其它尺寸同类型 1

THIS DRAWING IS A CONTROLLED DOCUMENT.		DWN 29OCT2014 David Wang		
DIMENSIONS: mm		CHK 29OCT2014 Chris Wang		
TOLERANCES UNLESS OTHERWISE SPECIFIED:		APVD 29OCT2014 Xiang Xu	NAME HDD-072-F	
0 PLC ±-		PRODUCT SPEC 108-137043	SIZE CAGE CODE DRAWING NO RESTRICTED TO	
1 PLC ±-		APPLICATION SPEC 114-137043	A300779 © T2030722201000	
2 PLC ±-		WEIGHT -	SCALE 1:1 SHEET 2 OF 2 REV B1	
3 PLC ±-		Customer Drawing		
4 PLC ±-				
ANGLES ±-				
FINISH				
MATERIAL				