

REVISIONS

P	LTR	DESCRIPTION	DATE	DWN	APVD
	A	INITIAL	21JAN2019	AL	CW
	AI	ECR-19-002478	16FEB2019	AL	CW
	B	ECR-21-111798	18SEP2021	WQR	CW

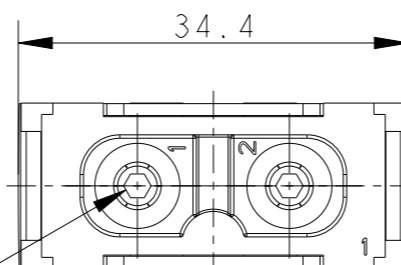
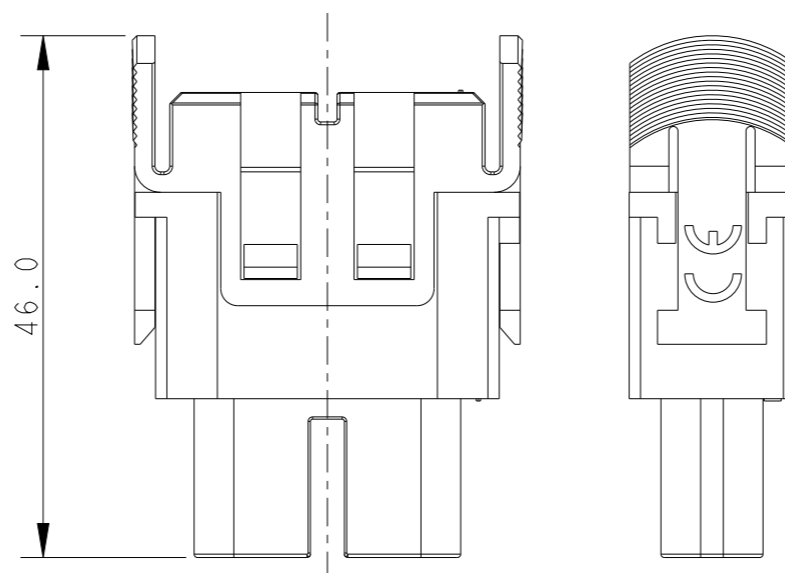
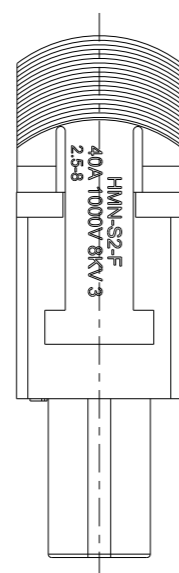
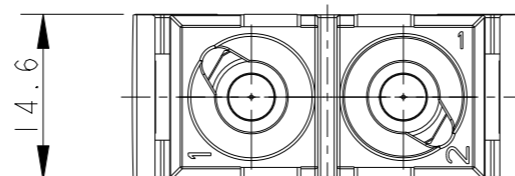
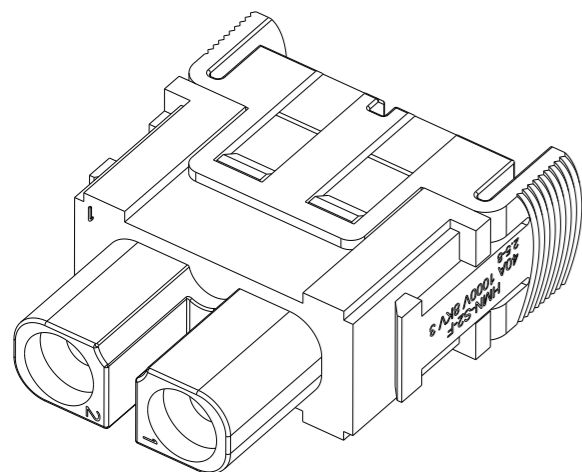

NOTES:

- TECHNICAL CHARACTERISTICS:  
 INSULATION MATERIAL: PC  
 RATED VOLTAGE: 1000V  
 RATED CURRENT: 40A  
 INSULATION RESISTANCE:  $\geq 400M\Omega$   
 RATED IMPULSE VOLTAGE: 8KV  
 POLLUTION DEGREE: 3  
 CONTACT RESISTANCE:  $\leq 3m\Omega$   
 FLAMMABILITY: UL94V-0  
 MATING CYCLES: 500  
 WIRE RANGE: 2.5~8mm<sup>2</sup>  
 CONTACT TYPE: AXIAL SCREW TYPE.

注释:

- 技术参数:  
 绝缘材料: PC  
 额定电压: 1000V  
 额定电流: 40A  
 绝缘电阻:  $\geq 400M\Omega$   
 脉冲电压: 8KV  
 污染等级: 3  
 接触电阻:  $\leq 3m\Omega$   
 阻燃等级: UL94V-0  
 插拔次数: 500  
 接线范围: 2.5~8mm<sup>2</sup>  
 接线类型: 轴向连接

2 X AXIAL SCREW TERMINATION  
 (HEXAGONAL DRIVER SW2)  
 RECOMMENDED TIGHTENING TORQUE 1.5-2Nm  
 2 X 轴向螺纹端子 (六角驱动 SW2), 推荐锁紧力矩 1.5-2Nm

S2111023201-000	HMN-S2-F, 2.5-8	HMN-S2 FEMALE MODULE INSERT, 2.5-8 HMN-S2 模块母插, 2.5-8
PART NUMBER 零件料号	PART DESCRIPTION 零件描述	

THIS DRAWING IS A CONTROLLED DOCUMENT.		DWN ANDY LIN 21JAN2019	 TE Connectivity	
DIMENSIONS: mm		CHK GINO YAO 21JAN2019		
TOLERANCES UNLESS OTHERWISE SPECIFIED:		APVD CHRIS WANG 21JAN2019	NAME HMN-S2-F, 2.5-8	
0 PLC ±-		PRODUCT SPEC 108-137123	SIZE A3	
1 PLC ±-		APPLICATION SPEC 114-137123	CAGE CODE 00779	DRAWING NO S2111023201000
2 PLC ±-		WEIGHT -	RESTRICTED TO -	
3 PLC ±-		CUSTOMER DRAWING	SCALE 3:2	SHEET 1 OF 1
4 PLC ±-				REV B
ANGLES ±-				
FINISH				
MATERIAL				